

# Technical bulletin

# TB-039

## Charging system Isuzu / Opel / Vauxhall

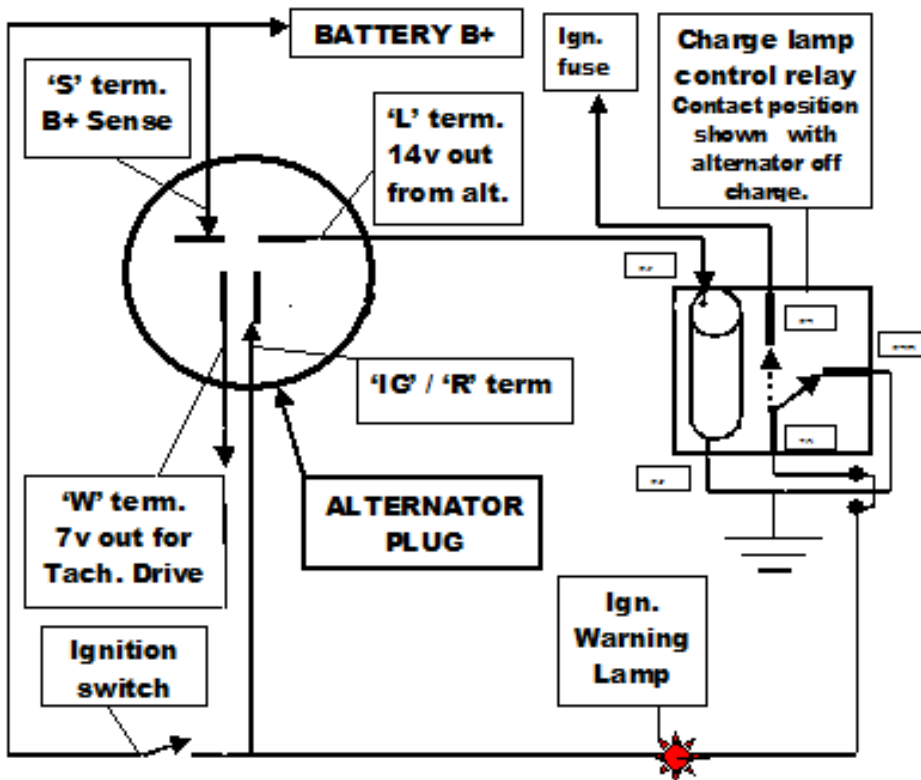

The charging system on most Isuzu, Opel and Vauxhall applications fitted with these alternators have a charge relay fitted in the circuit. One of the functions of this relay is to control the charging warning lamp. When the original alternator fails, it is possible for excessive voltage to be produced at the 'L' terminal, this high voltage can overheat/burnout the relay coil. The relay must be checked for serviceability before installing the replacement alternator. Failure to do so could prevent the replacement alternator from charging.

NOTE. The ignition supply is used to excite the alternator not the lamp circuit. Circuit above shows approximate correct operating voltages.