

Technical bulletin

TB-040

Charging system Isuzu / Opel / Vauxhall

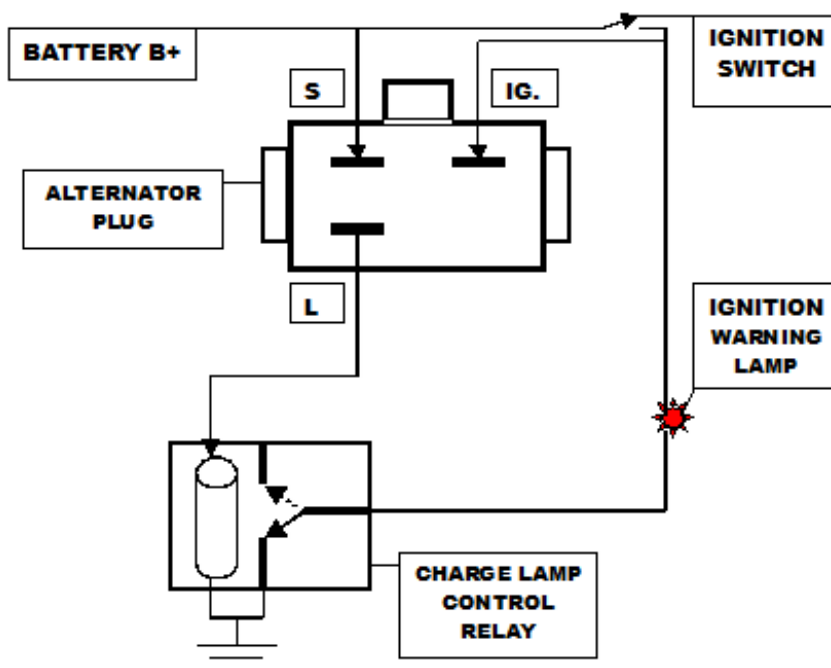

The charging system on most Isuzu, Opel and Vauxhall applications fitted with these alternators have a charge relay fitted in the circuit. One of the functions of the relay is to control the charge warning lamp. When the original alternator fails, it is possible for excessive voltage to be produced on the 'L' terminal, this high voltage can overheat/burnout the relay coil. The relay must be checked for serviceability before installing the replacement alternator. Failure to do so could prevent the replacement alternator from charging.

NOTE. The ignition circuit is used to excite the alternator, not the lamp circuit.